

# MIL-DTL-83723 Series III

## Features and Application

### Bayonet and Threaded Coupling



## Features and Application

MIL-DTL-83723 Series III family offers connectors with bayonet and threaded coupling including lanyard-release quick-disconnects. These connectors combine the best features of MIL-DTL-26500 and NAS 1599 miniature connector specifications. They are intermateable with both bayonet and threaded 26500 connectors (exception: shell size 8, threaded coupling only) and have the added advantage provided by the rear-release contact retention system.

AE833 connectors are widely used on commercial, military and aerospace systems requiring general-purpose, miniature cylindrical bayonet or threaded coupling connectors. In addition, Series III threaded connectors with self-locking plugs are well suited for engine applications.

This family of connectors (bayonet as well as threaded) is offered in wall mount receptacles as well as jam nut mounted receptacles which incorporate "O" ring seals, designed for rear panel "D" hole mounting.

Series III bayonet-coupling plugs are available in two designs - with and without RFI grounding. Threaded coupling plugs are offered with and without RFI grounding, self-locking and RFI/self-locking. In addition we offer quick-disconnect (lanyard release) plugs, which mate with threaded receptacles via an adapter.

Thirty-one insert arrangements per MIL-STD-1554 are tooled and qualified to MIL-DTL-83723 Series III, utilizing 2 to 61 M39029 contacts. Contacts come in sizes 20, 16 and 12, terminating wire sizes from 24 to 12 gauge.

These connectors are available in wide range of shell materials and finishes. Aluminum shells are offered in electroless nickel, olive drab cadmium and black anodic. Other finishes such as zinc nickel are available upon request to commercial callouts only. In addition, we offer passivated stainless steel shells with both standard and firewall-rated inserts, and for highly corrosive environments, nickel-aluminum-bronze shells with standard environment-resisting inserts (commercial callouts only).

**Universal I/R Tool** – A single, expendable plastic tool is used for both insertion and removal of contacts.

**Shell Polarization** – Alternate key/keyway positions prevent cross mating of adjacent connectors having same insert arrangement.

**Closed-Entry Socket Insert** – Hard dielectric socket face has lead-in chamfers for positive alignment of pins (even partially bent within pre-established limits) with sockets.

**Interfacial Pin Insert Seal** – Raised moisture barriers around each pin, which mate into lead-in chamfers of hard face socket insert, provide individual contact sealing. Interfacial seal is never touched by service tools.

**Elastomer Wire Sealing Grommet** – Sealing over a wide range of wire diameters is assured by a triple wire seal in each cavity at the rear of the connector.

**Superior Contact Stability** – Rear release crimp contact system features a stamped beryllium-copper retaining clip captivated by molded-in shoulders of each contact cavity in the insulator. A rear-inserted M81969 plastic tool expands the tines beyond the shoulder, releasing the contact.





# MIL-DTL-83723 Series III Performance Specifications Bayonet and Threaded Coupling

## Performance Specifications

### Operating Temperature Range

Classes A and R: -65°C to +200°C (-85°F to +392°F)  
 Class W: -65°C to +175°C (-85°F to +347°F)  
 Classes G and K: -65°C to +200°C (-85°F to +392°F)  
 Classes N and S: -65°C to +200°C (-85°F to +392°F)

### Material and Finish Data (Class)

A – aluminum shell, black anodized finish  
 G – stainless steel shell, passivated  
 K – stainless steel shell, passivated, firewall  
 R – aluminum shell, electroless nickel finish  
 S – stainless steel shell, passivated, firewall, and 360° teeth  
 W – aluminum shell, olive drab cadmium over nickel base  
 N – stainless steel shell, electrodeposited nickel, firewall, and 360° teeth

### Corrosion Resistance

Class W withstands 500-hour salt spray.  
 Class R withstands 48-hour salt spray.

### Environmental Seal

Wired, mated connectors with specified accessories attached, shall meet the altitude-immersion test specified by MIL-DTL-83723 Series III.

### Fluid Resistance

Connectors resist specified immersions in MIL-PRF-7808 (lubricating oil), MIL-PRF-23699 (lubricating oil), MIL-PRF-5606 (hydraulic fluid), M2-V Chevron oil, Coolanol 25, MIL-DTL-83133 (turbine fuel JP-8), MIL-DTL-5624 (turbine fuels JP-4 and JP-5), SAE-AMS1424 Type I (defrosting fluid), and other solvents and cleaning agents.

### Voltage Rating

Service Rating	Suggested Operating Voltage*		Test Voltage	Test Voltage	Test Voltage	Test Voltage
	(Sea Level)		Sea Level	50,000 Ft.	70,000 Ft.	110,000 Ft.
	AC (RMS)	DC	V RMS	V RMS	V RMS	V RMS
I	600	850	1500	500	375	200
II	900	1250	2300	750	500	200

\*To be used by designer only as a guide.

### Durability

Mated connectors withstand a minimum of 500 mating cycles for bayonet coupling straight plug (M83723/75, 76); 250 mating cycles for bayonet coupling RFI plug (M83723/77, 78); and 250 cycles for all threaded coupling plugs (M83723/86, 87, 91, 92, 95, 96, 97, 98).

### Shock and Vibration Requirements

Wired, mated connectors shall not be damaged, coupling ring shall not loosen, and there shall be no interruption of electrical continuity longer than one microsecond when subjected to the following:

### Shock

Mated connectors withstand a pulse of approximate half sine wave of 300 G ± 15 percent magnitude with duration of 3 ± 1 milliseconds applied in three axes.

### Vibration

Mated connectors withstand the following vibration levels:

- Random vibration per MIL-STD-1344, method 2005, test condition VI, letter J.

### Shielding Effectiveness

RFI attenuation at the specified frequency meets the requirements of MIL-DTL-83723 Series III.

- RFI shielding effectiveness of mated connectors with RFI backshells is measured in a triaxial radio frequency leakage fixture.

### Shell-to-Shell Conductivity (Except class A)

- With RFI spring fingers, the maximum potential drop shall not exceed 5 millivolts.
- Without spring fingers, the maximum potential drop shall not exceed 200 millivolts.

**MIL-DTL-83723 Series III**  
**Part Number Development**  
**Bayonet Coupling**



Military and Aero-Electric Part Number Development

<b>Mil. Prefix</b>	<b>M83723/</b>	<b>71</b>	<b>R</b>	<b>12</b>	<b>12</b>	<b>N</b>	
<b>Aero Prefix</b>	<b>AE833</b>	<b>71</b>	<b>R</b>	<b>12</b>	<b>12</b>	<b>N</b>	<b>-340</b>
<b>Shell type</b>							
71 = Wall mount receptacle with socket contacts							
72 = Wall mount receptacle with pin contacts							
73 = Jam nut receptacle with socket contacts							
74 = Jam nut receptacle with pin contacts							
75 = Straight plug with socket contacts							
76 = Straight plug with pin contacts							
77 = RFI grounding plug with socket contacts							
78 = RFI grounding plug with pin contacts							
<b>Class (Material and Finish)</b>							
A = Aluminum shell, black anodized finish (not available in 77 and 78 RFI plugs)							
G = Stainless steel shell, passivated							
R = Aluminum shell, electroless nickel finish							
W = Aluminum shell, olive drab cadmium over electroless nickel finish							
<b>Shell Size (SS)</b>							
8, 10, 12, 14, 16, 18, 20, 22 or 24							
<b>Insert Arrangement</b>							
See pages 106 thru 108							
<b>Polarization (Keying)</b>							
N = Normal							
6, 7, 8, 9 or Y (Alternate keyed positions, Y is not available in SS 8)							
1, 2, 3, 4 or 5 (Cloned insert polarizations within normally keyed shell, not approved for new design, n/a in SS 8)							
<b>Modification (applies to Aero part numbers only)</b>							
01 = Less contacts (Part is bagged and tagged, but not marked with 01)							
340 = Connector kitted with M85049/31-XXX E-nut							
341 = Connector kitted with M85049/52-1-XXX straight clamp							
342 = Connector kitted with M85049/51-1-XXX right angle clamp							
Consult factory for other modifications							

**Note 1:** Each connector is furnished with contacts unless ordered less contacts (L/C) as follows: One spare contact for inserts requiring 2 to 26 of each contact and two spares for inserts with 27 or more of each size, and a minimum of one sealing plug up to 15% of the number of contacts of each size. In addition, one insertion/removal tool of each size is included.

**Note 2:** Proper part number marking has no “0” in front of single digit shell size (8), but it does include the “0” in front of single digit layout. Examples: M83723/72W803N and M83723/77G10056. Please note that in this series “N” for normal is included in part number marking.

Bayonet Coupling, Crimp Removable, Rear Release

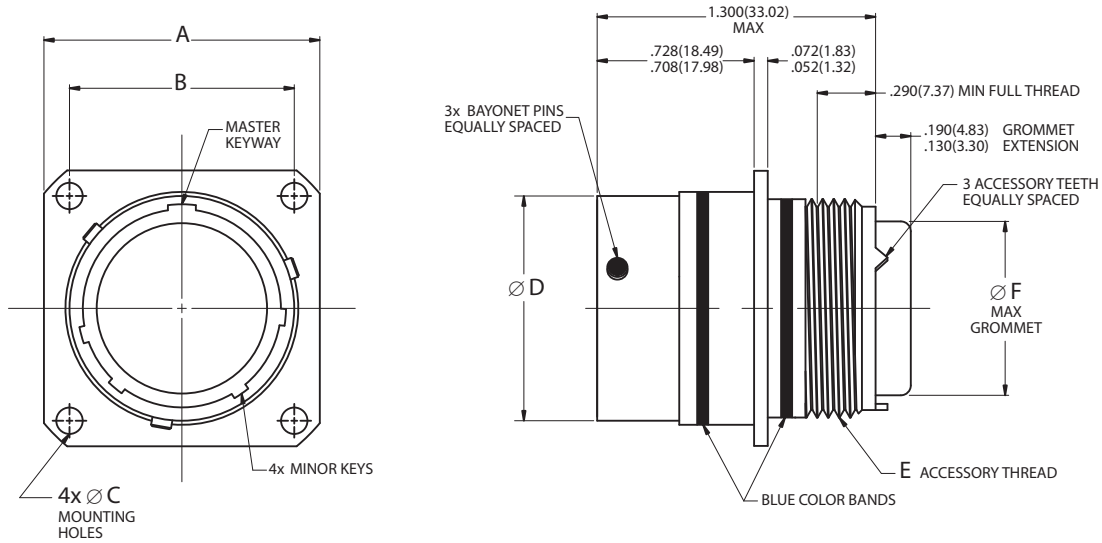

Page 88 Completed Part Number  
 Page 104 Contacts, Sealing Plugs and Tools  
 Pages 107, 108 Insert Arrangements  
 Page 87 Performance Specifications  
 Page 106 Insert Availability and Contact Information  
 Page 102 Polarization

Shell Size	A		B		Ø C		Ø D		E	Ø F	
	±.005	±.13	(TP)		±.005	±.13	+.000	+.00	Accessory Thread Class 2A	Maximum	
	inch	mm	inch	mm	inch	mm	inch	mm		inch	mm
8	.812	20.62	.594	15.09	.120	3.05	.536	13.61	1/2-20UNF	.305	7.75
10	.937	23.80	.719	18.26	.120	3.05	.659	16.74	5/8-24UNEF	.405	10.29
12	1.031	26.19	.812	20.62	.120	3.05	.829	21.06	3/4-20UNEF	.531	13.49
14	1.125	28.58	.906	23.01	.120	3.05	.898	22.81	7/8-20UNEF	.665	16.89
16	1.250	31.75	.969	24.61	.120	3.05	1.025	26.04	1-20UNEF	.790	20.07
18	1.343	34.11	1.062	26.97	.120	3.05	1.131	28.73	1-1/16-18UNEF	.869	22.07
20	1.437	36.50	1.156	29.36	.120	3.05	1.256	31.90	1-3/16-18UNEF	.994	25.25
22	1.562	39.67	1.250	31.75	.120	3.05	1.381	35.08	1-5/16-18UNEF	1.119	28.42
24	1.703	43.26	1.375	34.93	.149	3.78	1.506	38.25	1-7/16-18UNEF	1.244	31.60

**M83723/73, 74**  
**Jam Nut Receptacle**  
**AE83373, 74**



**Bayonet Coupling, Crimp Removable, Rear Release**

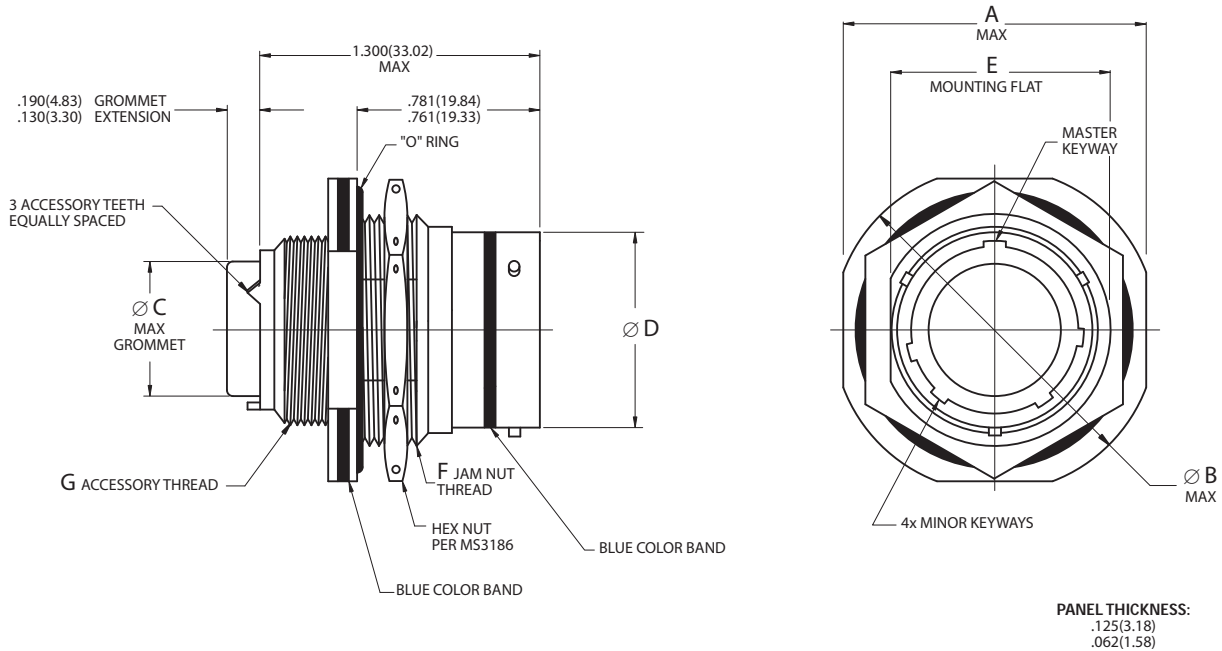

- Page 88 Completed Part Number
- Page 104 Contacts, Sealing Plugs and Tools
- Pages 107, 108 Insert Arrangements
- Page 87 Performance Specifications
- Page 106 Insert Availability and Contact Information
- Page 102 Polarization

MIL-DTL-83723 S III

Shell Size	A		Ø B		Ø C		Ø D		E		F	G
	Maximum		Maximum		Maximum		+0.000	+0.00	±.003	±.08	Jam Nut Thread Class 2A	Accessory Thread Class 2A
	inch	mm	inch	mm	inch	mm	inch	mm				
8	.979	24.87	1.068	27.13	.305	7.75	.536	13.61	.593	15.06	5/8-20UN	1/2-20UNF
10	1.104	28.04	1.192	30.28	.405	10.29	.659	16.74	.718	18.24	3/4-20UNEF	5/8-24UNEF
12	1.291	32.79	1.380	35.05	.531	13.49	.829	21.06	.905	22.99	15/16-20UNEF	3/4-20UNEF
14	1.391	35.33	1.505	38.23	.665	16.89	.898	22.81	.968	24.59	1-20UNEF	7/8-20UNEF
16	1.516	38.51	1.630	41.40	.790	20.07	1.025	26.04	1.093	27.76	1-1/8-20UN	1-20UNEF
18	1.641	41.68	1.756	44.60	.869	22.07	1.131	28.73	1.217	30.91	1-1/4-18UNEF	1-1/16-18UNEF
20	1.766	44.86	1.860	47.24	.994	25.25	1.256	31.90	1.342	34.09	1-3/8-18UNEF	1-3/16-18UNEF
22	1.954	49.63	2.086	52.98	1.119	28.42	1.381	35.08	1.467	37.26	1-1/2-18UNEF	1-5/16-18UNEF
24	2.079	52.81	2.160	54.86	1.244	31.60	1.506	38.25	1.592	40.44	1-5/8-18UNEF	1-7/16-18UNEF

Bayonet Coupling, Crimp Removable, Rear Release

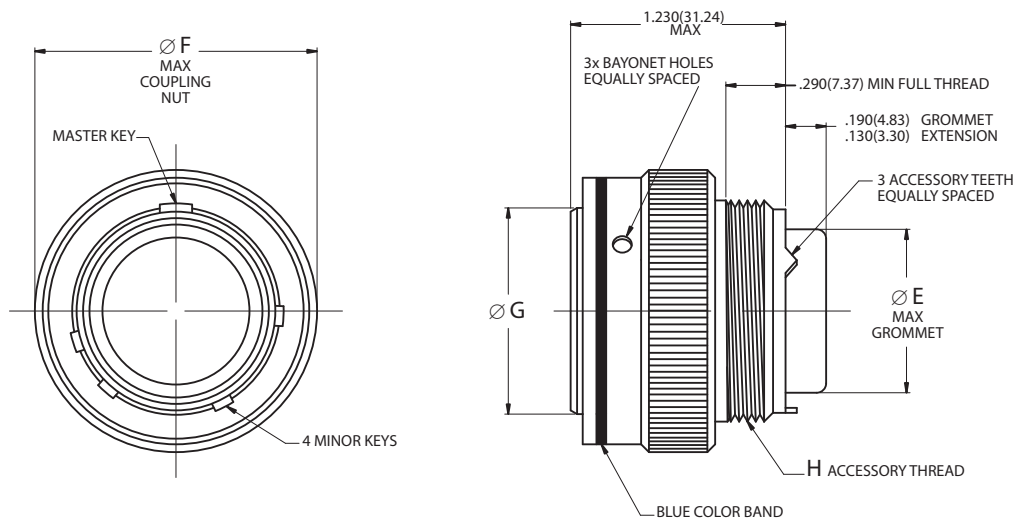

Page 88 Completed Part Number  
 Page 104 Contacts, Sealing Plugs and Tools  
 Pages 107, 108 Insert Arrangements  
 Page 87 Performance Specifications  
 Page 106 Insert Availability and Contact Information  
 Page 102 Polarization

Shell Size	Ø E		Ø F		Ø G		H
	Maximum		Maximum		+0.005	+0.13	Accessory Thread Class 2A
	inch	mm	inch	mm	-0.004	-0.10	
8	.305	7.75	.776	19.71	.419	10.64	1/2-20UNF
10	.405	10.29	.906	23.01	.521	13.23	5/8-24UNEF
12	.531	13.49	1.078	27.38	.691	17.55	3/4-20UNEF
14	.665	16.89	1.141	28.98	.760	19.30	7/8-20UNEF
16	.790	20.07	1.266	32.16	.887	22.53	1-20UNEF
18	.869	22.07	1.375	34.93	.993	25.22	1-1/16-18UNEF
20	.994	25.25	1.510	38.35	1.118	28.40	1-3/16-18UNEF
22	1.119	28.42	1.625	41.28	1.243	31.57	1-5/16-18UNEF
24	1.244	31.60	1.760	44.70	1.368	34.75	1-7/16-18UNEF

**M83723/77, 78**  
**RFI Grounding Plug**  
**AE83377, 78**



Bayonet Coupling, Crimp Removable, Rear Release

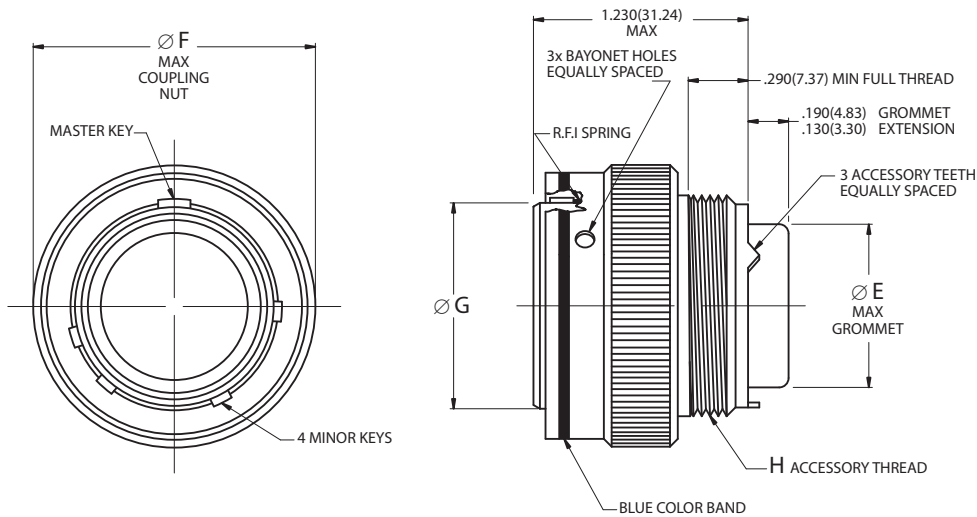

- Page 88 Completed Part Number
- Page 104 Contacts, Sealing Plugs and Tools
- Pages 107, 108 Insert Arrangements
- Page 87 Performance Specifications
- Page 106 Insert Availability and Contact Information
- Page 102 Polarization

MIL-DTL-83723 S III

Shell Size	$\varnothing E$		$\varnothing F$		$\varnothing G$		H
	Maximum		Maximum		+.005	+.13	
	inch	mm	inch	mm	-.004	-.10	Accessory Thread Class 2A
8	.305	7.75	.776	19.71	.419	10.64	1/2-20UNF
10	.405	10.29	.906	23.01	.521	13.23	5/8-24UNEF
12	.531	13.49	1.078	27.38	.691	17.55	3/4-20UNEF
14	.665	16.89	1.141	28.98	.760	19.30	7/8-20UNEF
16	.790	20.07	1.266	32.16	.887	22.53	1-20UNEF
18	.869	22.07	1.375	34.93	.993	25.22	1-1/16-18UNEF
20	.994	25.25	1.510	38.35	1.118	28.40	1-3/16-18UNEF
22	1.119	28.42	1.625	41.28	1.243	31.57	1-5/16-18UNEF
24	1.244	31.60	1.760	44.70	1.368	34.75	1-7/16-18UNEF



# MIL-DTL-83723 Series III Part Number Development Threaded Coupling

## Military and Aero-Electric Part Number Development

<b>Mil. Prefix</b>	<b>M83723/</b>	<b>95</b>	<b>R</b>	<b>12</b>	<b>12</b>	<b>N</b>	
<b>Aero Prefix</b>	<b>AE833</b>	<b>95</b>	<b>R</b>	<b>12</b>	<b>12</b>	<b>N</b>	<b>-340</b>
<b>Shell type</b>							
82 = Wall mount receptacle with socket contacts							
83 = Wall mount receptacle with pin contacts							
84 = Jam nut receptacle with socket contacts							
85 = Jam nut receptacle with pin contacts							
86 = Straight plug with socket contacts							
87 = Straight plug with pin contacts							
91 = RFI grounding plug with socket contacts							
92 = RFI grounding plug with pin contacts							
95 = Self-locking plug with socket contacts							
96 = Self-locking plug with pin contacts							
97 = Self-locking, RFI grounding plug with socket contacts							
98 = Self-locking, RFI grounding plug with pin contacts							
68 = Lanyard release, quick-disconnect plug, pin (not available in K & S classes)							
69 = Lanyard release, quick-disconnect plug, socket (not available in K & S classes)							
<b>Class (Material and Finish)</b>							
A = Aluminum shell, black anodized finish (Not available in 91, 92, 97 & 98 RFI plugs)							
G = Stainless steel shell, passivated (n/a in 97 & 98)							
K = Stainless steel shell, passivated, with firewall rated insert (n/a in 91, 92, 97 & 98)							
R = Aluminum shell, electroless nickel finish (n/a in 97 & 98 to mil number)							
W = Aluminum shell, olive drab cadmium over nickel base (n/a in 97 & 98 to mil number)							
S = Stainless steel shell, passivated, full teeth, firewall insert (n/a in 86, 87, 91, 92, 95 & 96)							
<b>Shell Size (SS)</b>							
8, 10, 12, 14, 16, 18, 20, 22 or 24 (and shell size 28 available in Aero p/n only)							
<b>Insert Arrangement</b>							
See pages 106-108							
<b>Polarization (Keying)</b>							
N = Normal							
6, 7, 8, 9 or Y (Alternate keyed positions, Y is not available in SS 8)							
1, 2, 3, 4 or 5 (Clocked insert polarizations within normally keyed shell, not approved for new design, n/a in SS 8)							
<b>Modification (applies to Aero part numbers only)</b>							
01 = Less contacts (Part is bagged and tagged, but not marked with 01)							
340 = Connector kitted with M85049/31-XXX E-nut							
341 = Connector kitted with M85049/52-1-XXX straight clamp							
342 = Connector kitted with M85049/51-1-XXX right angle clamp							
Consult factory for other modifications							

**Note 1:** Each connector is furnished with contacts unless ordered less contacts (L/C) as follows: One spare contact for inserts requiring 2 to 26 of each contact and two spares for inserts with 27 or more of each size, and a minimum of one sealing plug up to 15% of the number of contacts of each size. In addition, one insertion/removal tool of each size is included.

**Note 2:** Proper part number marking has no “0” in front of single digit shell size (8), but it does include the “0” in front of single digit layout. Examples: M83723/95G803N and M83723/98S10056. Please note that in this series “N” for normal is included in part number marking.

**Note 3:** Shell type M83723/70 (AE83370 Receptacle Adapter) is not listed above, see page 101.



**M83723/82, 83**  
**Wall Mounting Receptacle**  
**AE83382, 83**



**Threaded Coupling, Crimp Removable, Rear Release**

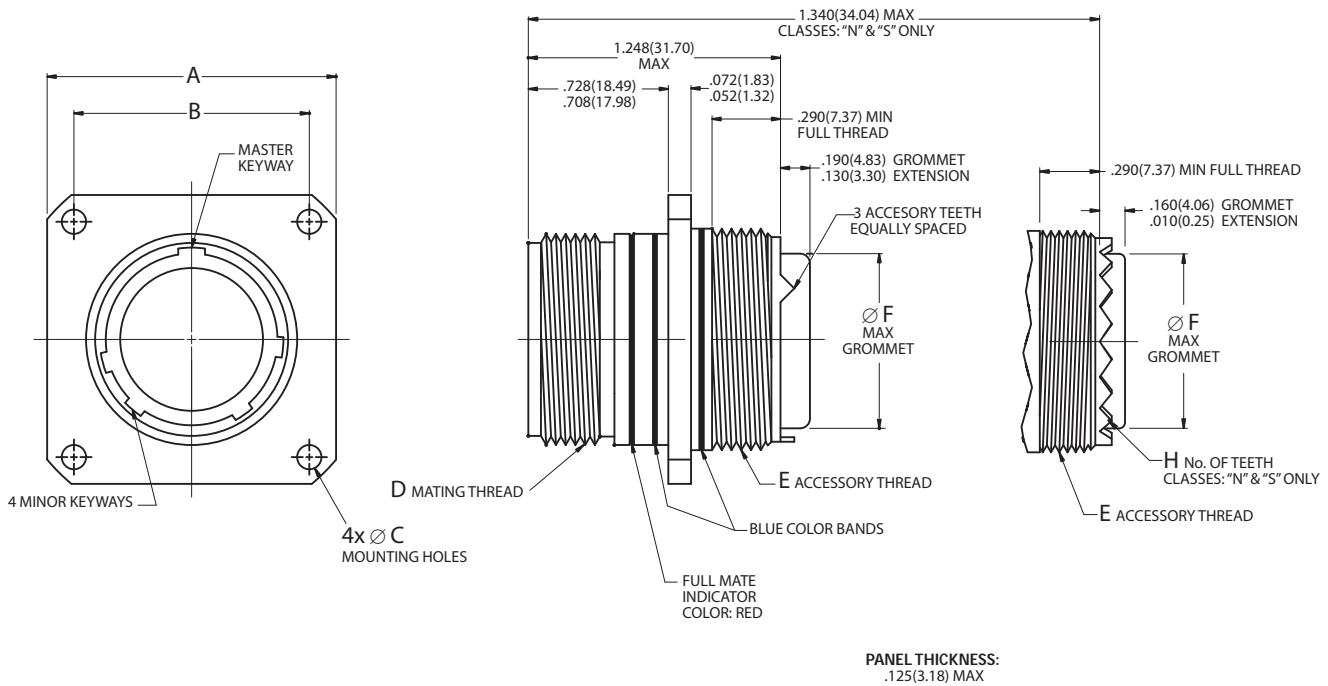

- Page 93 Completed Part Number
- Page 104 Contacts, Sealing Plugs and Tools
- Pages 107, 108 Insert Arrangements
- Page 87 Performance Specifications
- Page 106 Insert Availability and Contact Information
- Page 102 Polarization

Shell Size	A		B		Ø C		D	E	Ø F		H
	±.005	±.13	(TP)		+0.005	+0.13	Mating Thread	Accessory Thread	Maximum		No. of Teeth
	inch	mm	inch	mm	inch	mm	Class 2A	Class 2A	inch	mm	
8	.812	20.62	.594	15.09	.120	3.05	9/16-24UNEF	1/2-20UNF	.305	7.75	12
10	.937	23.80	.719	18.26	.120	3.05	11/16-24UNEF	5/8-24UNEF	.405	10.29	15
12	1.031	26.19	.812	20.62	.120	3.05	7/8-20UNEF	3/4-20UNEF	.531	13.49	21
14	1.125	28.58	.906	23.01	.120	3.05	15/16-20UNEF	7/8-20UNEF	.665	16.89	24
16	1.250	31.75	.969	24.61	.120	3.05	1-1/16-18UNEF	1-20UNEF	.790	20.07	30
18	1.343	34.11	1.062	26.97	.120	3.05	1-3/16-18UNEF	1-1/16-18UNEF	.869	22.07	33
20	1.437	36.50	1.156	29.36	.120	3.05	1-5/16-18UNEF	1-3/16-18UNEF	.994	25.25	36
22	1.562	39.67	1.250	31.75	.120	3.05	1-7/16-18UNEF	1-5/16-18UNEF	1.119	28.42	39
24	1.703	43.26	1.375	34.93	.149	3.78	1-9/16-18UNEF	1-7/16-18UNEF	1.244	31.60	42
28	2.000	50.80	1.562	39.67	.149	3.78	1-13/16-16UN	1-3/4-18UNS	1.475	37.47	54

Threaded Coupling, Crimp Removable, Rear Release

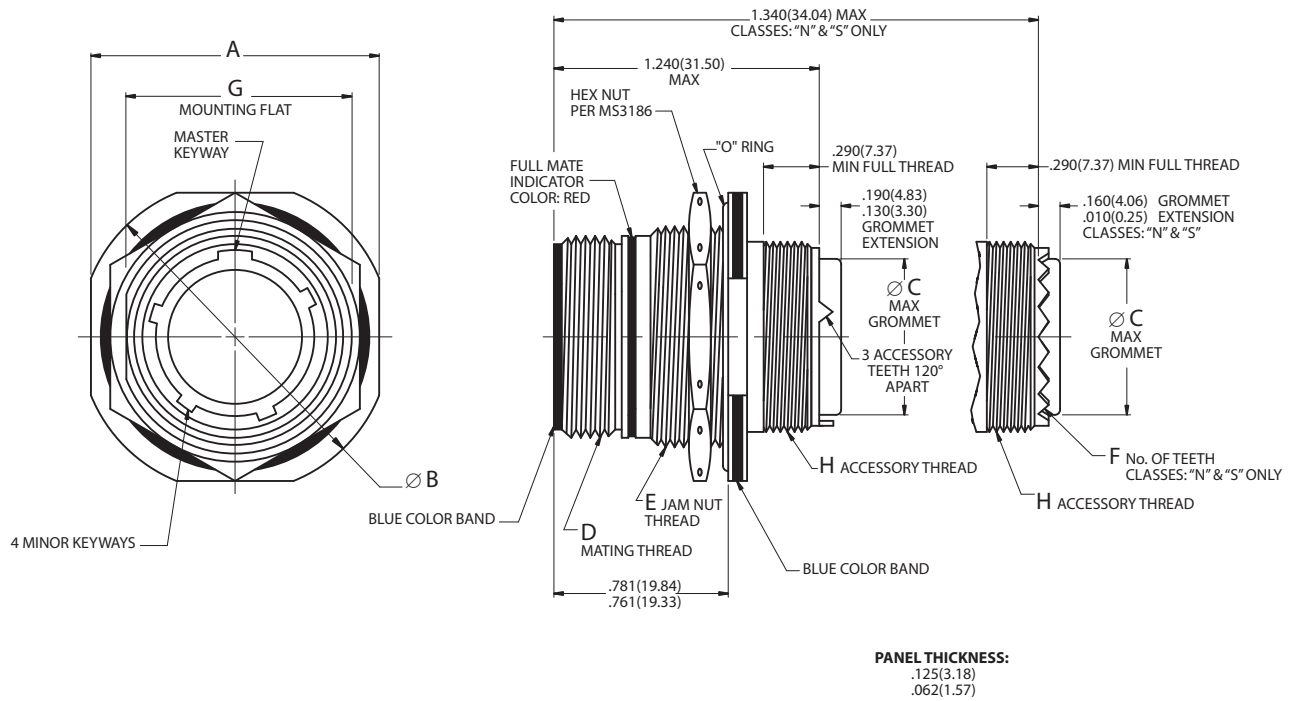

- Page 93 Completed Part Number
- Page 104 Contacts, Sealing Plugs and Tools
- Pages 107, 108 Insert Arrangements
- Page 87 Performance Specifications
- Page 106 Insert Availability and Contact Information
- Page 102 Polarization

Shell Size	A		Ø B		Ø C		D	E	F	G		H
	+0.016	<b>+0.41</b>	+0.016	<b>+0.41</b>	Maximum	Mating Thread Class 2A	Jam Nut Thread Class 2A	No. of Teeth	±.003	±.08	Accessory Thread Class 2A	
	-.015	<b>-0.38</b>	-.015	<b>-0.38</b>						inch		<b>mm</b>
inch	<b>mm</b>	inch	<b>mm</b>	inch	<b>mm</b>	inch	<b>mm</b>	inch	<b>mm</b>	inch	<b>mm</b>	
8	.964	<b>24.49</b>	1.062	<b>26.97</b>	.305	<b>7.75</b>	9/16-24UNEF	5/8-20UN	12	.593	<b>15.06</b>	1/2-20UNF
10	1.088	<b>27.64</b>	1.176	<b>29.87</b>	.405	<b>10.29</b>	11/16-24UNEF	3/4-20UNEF	15	.718	<b>18.24</b>	5/8-24UNEF
12	1.275	<b>32.39</b>	1.364	<b>34.65</b>	.531	<b>13.49</b>	7/8-20UNEF	15/16-20UNEF	21	.905	<b>22.99</b>	3/4-20UNEF
14	1.375	<b>34.93</b>	1.545	<b>39.24</b>	.665	<b>16.89</b>	15/16-20UNEF	1-20UNEF	24	.968	<b>24.59</b>	7/8-20UNEF
16	1.500	<b>38.10</b>	1.625	<b>41.28</b>	.790	<b>20.07</b>	1-1/16-18UNEF	1-1/8-18UNEF	30	1.093	<b>27.76</b>	1-20UNEF
18	1.625	<b>41.28</b>	1.750	<b>44.45</b>	.869	<b>22.07</b>	1-3/16-18UNEF	1-1/4-18UNEF	33	1.217	<b>30.91</b>	1-1/16-18UNEF
20	1.750	<b>44.45</b>	1.938	<b>49.23</b>	.994	<b>25.25</b>	1-5/16-18UNEF	1-3/8-18UNEF	36	1.342	<b>34.09</b>	1-3/16-18UNEF
22	1.938	<b>49.23</b>	2.062	<b>52.37</b>	1.119	<b>28.42</b>	1-7/16-18UNEF	1-1/2-18UNEF	39	1.467	<b>37.26</b>	1-5/16-18UNEF
24	2.063	<b>52.40</b>	2.166	<b>55.02</b>	1.244	<b>31.60</b>	1-9/16-18UNEF	1-5/8-18UNEF	42	1.592	<b>40.44</b>	1-7/16-18UNEF
28	2.314	<b>58.78</b>	2.428	<b>61.67</b>	1.475	<b>37.47</b>	1-13/16-16UN	1-7/8-20UN	54	1.840	<b>46.74</b>	1-3/4-18UNS

**M83723/86, 87**  
**Straight Plug**  
**AE83386, 87**



**Threaded Coupling, Crimp Removable, Rear Release**

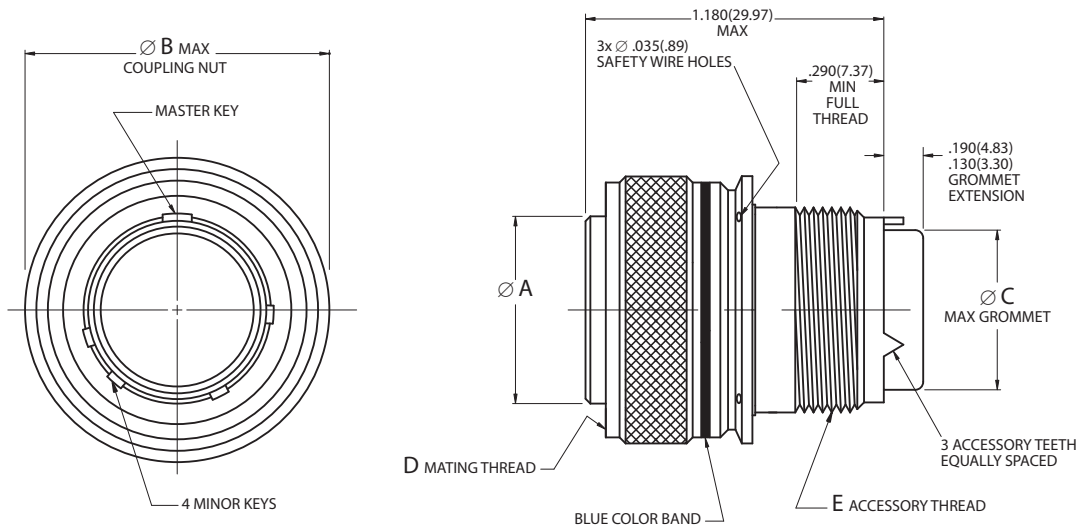

Page 93	Completed Part Number
Page 104	Contacts, Sealing Plugs and Tools
Pages 107, 108	Insert Arrangements
Page 87	Performance Specifications
Page 106	Insert Availability and Contact Information
Page 102	Polarization

Shell Size	Ø A		Ø B		Ø C		D	E
	+0.005	<b>+13</b>	Maximum	Maximum	Maximum	Maximum	Mating Thread Class 2B	Accessory Thread Class 2A
	-0.004	<b>-.10</b>						
8	.400	<b>10.16</b>	.776	<b>19.71</b>	.305	<b>7.75</b>	9/16-24UNEF	1/2-20UNF
10	.521	<b>13.23</b>	.906	<b>23.01</b>	.405	<b>10.29</b>	11/16-24UNEF	5/8-24UNEF
12	.691	<b>17.55</b>	1.078	<b>27.38</b>	.531	<b>13.49</b>	7/8-20UNEF	3/4-20UNEF
14	.760	<b>19.30</b>	1.141	<b>28.98</b>	.665	<b>16.89</b>	15/16-20UNEF	7/8-20UNEF
16	.887	<b>22.53</b>	1.266	<b>32.16</b>	.790	<b>20.07</b>	1-1/16-18UNEF	1-20UNEF
18	.993	<b>25.22</b>	1.375	<b>34.93</b>	.869	<b>22.07</b>	1-3/16-18UNEF	1-1/16-18UNEF
20	1.118	<b>28.40</b>	1.510	<b>38.35</b>	.994	<b>25.25</b>	1-5/16-18UNEF	1-3/16-18UNEF
22	1.243	<b>31.57</b>	1.625	<b>41.28</b>	1.119	<b>28.42</b>	1-7/16-18UNEF	1-5/16-18UNEF
24	1.368	<b>34.75</b>	1.760	<b>44.70</b>	1.244	<b>31.60</b>	1-9/16-18UNEF	1-7/16-18UNEF
28	1.618	<b>41.10</b>	2.050	<b>52.07</b>	1.475	<b>37.47</b>	1-13/16-16UN	1-3/4-18UNS

Threaded Coupling, Crimp Removable, Rear Release

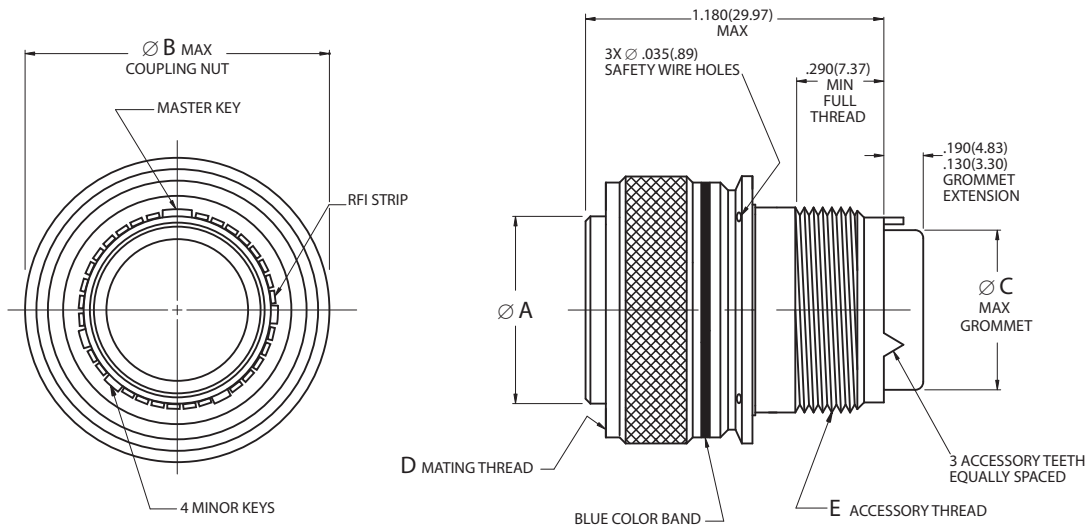

Page 93 Completed Part Number  
 Page 104 Contacts, Sealing Plugs and Tools  
 Pages 107, 108 Insert Arrangements  
 Page 87 Performance Specifications  
 Page 106 Insert Availability and Contact Information  
 Page 102 Polarization

Shell Size	Ø A		Ø B		Ø C		D	E
	+0.05	<b>+1.3</b>	Maximum	Maximum	Maximum	Maximum	Mating Thread Class 2B	Accessory Thread Class 2A
	-.004	<b>-.10</b>						
8	.400	<b>10.16</b>	.776	<b>19.71</b>	.305	<b>7.75</b>	9/16-24UNEF	1/2-20UNF
10	.521	<b>13.23</b>	.906	<b>23.01</b>	.405	<b>10.29</b>	11/16-24UNEF	5/8-24UNEF
12	.691	<b>17.55</b>	1.078	<b>27.38</b>	.531	<b>13.49</b>	7/8-20UNEF	3/4-20UNEF
14	.760	<b>19.30</b>	1.141	<b>28.98</b>	.665	<b>16.89</b>	15/16-20UNEF	7/8-20UNEF
16	.887	<b>22.53</b>	1.266	<b>32.16</b>	.790	<b>20.07</b>	1-1/16-18UNEF	1-20UNEF
18	.993	<b>25.22</b>	1.375	<b>34.93</b>	.869	<b>22.07</b>	1-3/16-18UNEF	1-1/16-18UNEF
20	1.118	<b>28.40</b>	1.510	<b>38.35</b>	.994	<b>25.25</b>	1-5/16-18UNEF	1-3/16-18UNEF
22	1.243	<b>31.57</b>	1.625	<b>41.28</b>	1.119	<b>28.42</b>	1-7/16-18UNEF	1-5/16-18UNEF
24	1.368	<b>34.75</b>	1.760	<b>44.70</b>	1.244	<b>31.60</b>	1-9/16-18UNEF	1-7/16-18UNEF
28	1.618	<b>41.10</b>	2.050	<b>52.07</b>	1.475	<b>37.47</b>	1-13/16-16UN	1-3/4-18UNS





**M83723/68, 69**

**Lanyard Release, Quick-Disconnect Plug**

**AE83368, 69**



Quick-Disconnect, Threaded Coupling, Crimp Removable, Rear Release

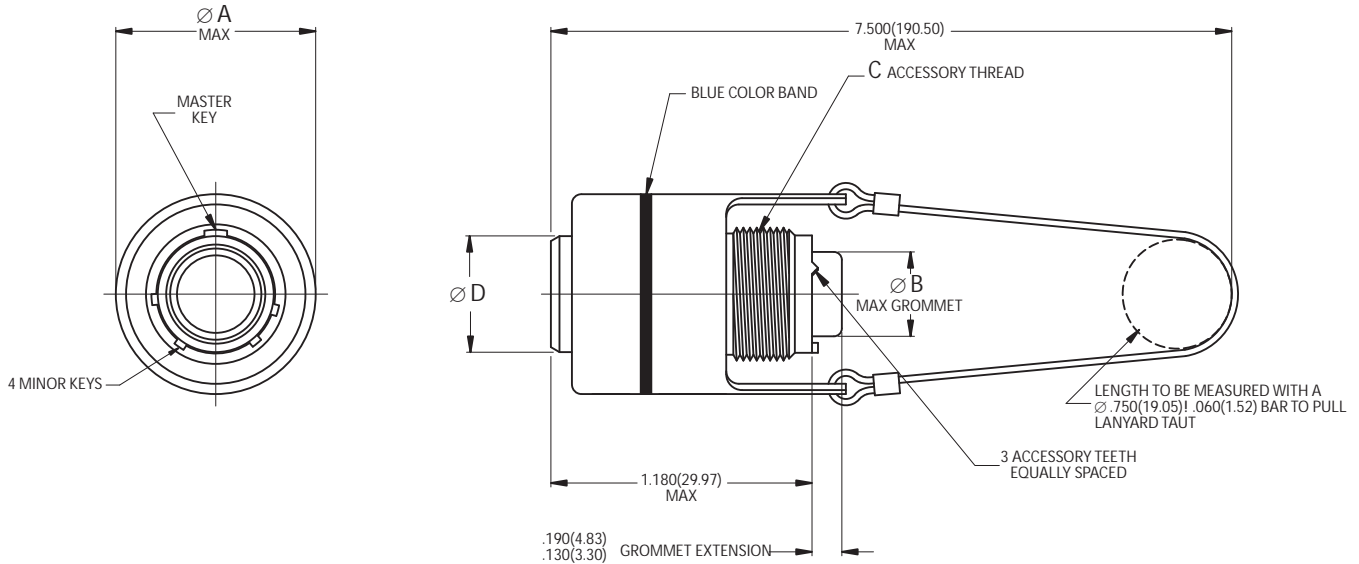

- Page 93 Completed Part Number
- Page 104 Contacts, Sealing Plugs and Tools
- Pages 107, 108 Insert Arrangements
- Page 87 Performance Specifications
- Page 106 Insert Availability and Contact Information
- Page 102 Polarization

**Note 1:** M83723/70 receptacle adapter (page 101) is required to mate the Quick-Disconnect Plug with a receptacle.

**Note 2:** Not available in shell size 8.

Shell Size	$\varnothing A$		$\varnothing B$		C Accessory Thread Class 2A	$\varnothing D$	
	Maximum		Maximum				
	inch	mm	inch	mm		inch	mm
10	1.240	31.50	.405	10.29	5/8-24UNEF	.526/.517	13.36/13.13
12	1.432	36.37	.531	13.49	3/4-20UNEF	.696/.687	17.68/17.45
14	1.490	37.85	.665	16.89	7/8-20UNEF	.765/.756	19.43/19.20
16	1.711	43.46	.790	20.07	1-20UNEF	.892/.883	22.66/22.43
18	1.815	46.10	.869	22.07	1-1/16-18UNEF	.998/.989	25.35/25.12
20	1.962	49.83	.994	25.25	1-3/16-18UNEF	1.123/1.114	28.52/28.30
22	2.070	52.58	1.119	28.42	1-5/16-18UNEF	1.248/1.239	31.70/31.47
24	2.195	55.75	1.244	31.60	1-7/16-18UNEF	1.373/1.364	34.87/34.65

Quick-Disconnect (Push-Pull) Receptacle Adapter

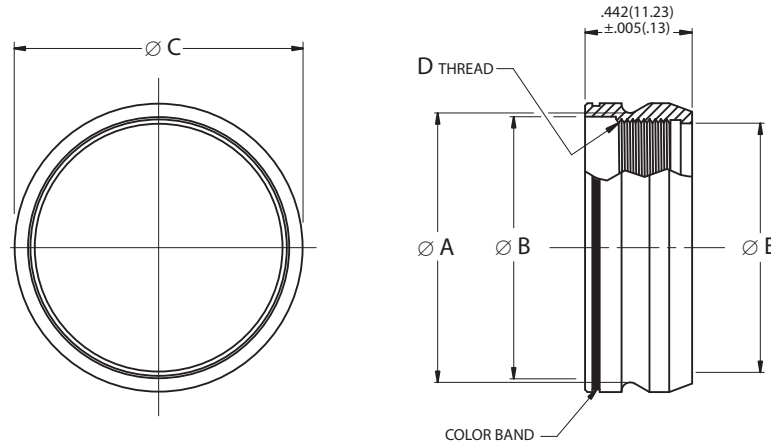

<b>Mil Prefix</b>	<b>M83723/</b>	<b>70</b>	<b>W</b>	<b>10</b>
<b>Aero Prefix</b>	<b>AE833</b>	<b>70</b>	<b>W</b>	<b>10</b>
<b>Specification Sheet (Shell type)</b>				
70 = Receptacle adapter, quick-disconnect				
<b>Class (Material and Finish)</b>				
A = Aluminum shell, black anodized finish				
G = Stainless steel shell, passivated				
R = Aluminum shell, electroless nickel finish				
W = Aluminum shell, cadmium olive drab over nickel base				
<b>Shell Size</b>				
8, 10, 12, 14, 16, 18, 20, 22 or 24				

**Note:** The adapter is required to mate the Lanyard Release and Push-Pull Quick-Disconnect plugs (M83723/66 thru 69) with M83723/82, 83, 84, 85, 88, 89 and 90 threaded coupling receptacles. Use compatible thread seizing compound to permanently secure to the receptacle.

Shell Size	D	Ø A		Ø B		Ø C		Ø E	
	Coupling Thread Class 2B	±.002	±.05	±.002	±.05	±.002	±.05	±.005	±.13
		inch	mm	inch	mm	inch	mm	inch	mm
8	9/16-24UNEF	.605	15.37	.577	14.66	.687	17.45	.525	13.34
10	11/16-24UNEF	.730	18.54	.712	18.08	.812	20.62	.650	16.51
12	7/8-20UNEF	.917	23.29	.892	22.66	.999	25.37	.840	21.34
14	15/16-20UNEF	.980	24.89	.952	24.18	1.062	26.97	.900	22.86
16	1-1/16-18UNEF	1.105	28.07	1.077	27.36	1.187	30.15	1.025	26.04
18	1-3/16-18UNEF	1.230	31.24	1.202	30.53	1.328	33.73	1.150	29.21
20	1-5/16-18UNEF	1.355	34.42	1.327	33.71	1.453	36.91	1.275	32.39
22	1-7/16-18UNEF	1.480	37.59	1.452	36.88	1.578	40.08	1.400	35.56
24	1-9/16-18UNEF	1.605	40.77	1.577	40.06	1.703	43.26	1.525	38.74



**MIL-DTL-83723 Series III**  
**Polarization (Shell Keying, Insert Clocking)**  
**Bayonet and Threaded**

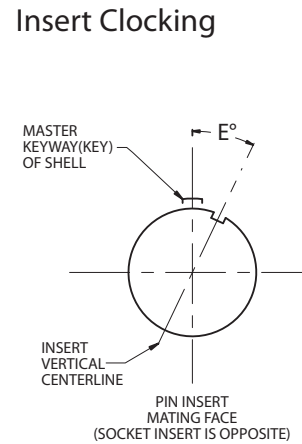
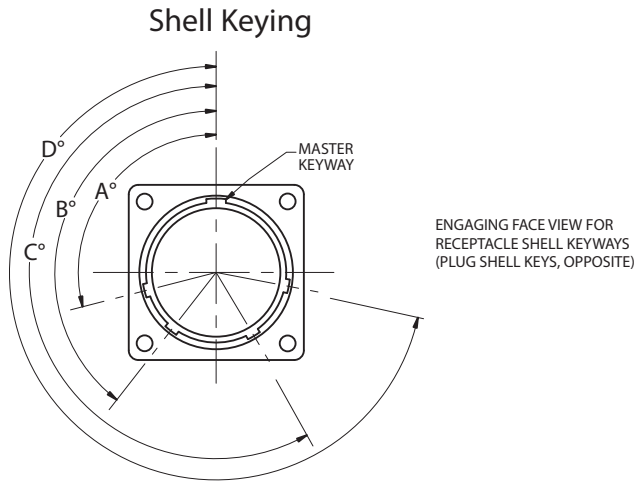

**Notes:**

1. In the normal position (N), the insert centerline coincides with the centerline of the master keyway (key) of the shell.  $E = 0^\circ$
2. In the alternate keying positions (6, 7, 8, 9 and Y), the minor keyways (keys) are positioned with reference to master keyway (key) as indicated in the keying position table below.
3. In the alternate insert clocking positions (1, 2, 3, 4 and 5), the pin insert (viewing from the mating side) is rotated counter-clockwise relative to the centerline of the master keyway (key) of the shell. The socket insert is rotated clockwise.

Shell Size	Polarizing	Key/Keyway Positions				Insert Position
	Position	A°	B°	C°	D°	E°
8*, 10	N	105	140	215	265	0
	6	102	132	248	320	0
	7	80	118	230	312	0
	8	35	140	205	275	0
	9	64	155	234	304	0
10 only	Y	25	115	220	270	0
12 thru 24, 28**	N	105	140	215	265	0
	6	18	149	192	259	0
	7	92	152	222	342	0
	8	84	152	204	334	0
	9	24	135	189	240	0
	Y	98	152	268	338	0
10 thru 24	1†	105	140	215	265	10
	2†	105	140	215	265	20
	3†	105	140	215	265	30
	4†	105	140	215	265	40
	5†	105	140	215	265	50

\* Per MIL-STD-1554, keyed position Y and clocked positions 1, 2, 3, 4 and 5 are not available in shell size 8.

† Per MIL-STD-1554, insert positions 1 thru 5 are inactive for new design.

\*\* Shell size 28 is not from military standard. It is only available in threaded family to Aero-Electric part number.

**Note:** Alternate positions “Z” and “10” are cancelled and superseded by Position “Y”.



# MIL-DTL-83723 Series III, Bayonet and Threaded Flange and Jam Nut Receptacles Panel Cutouts

## Panel Cutouts

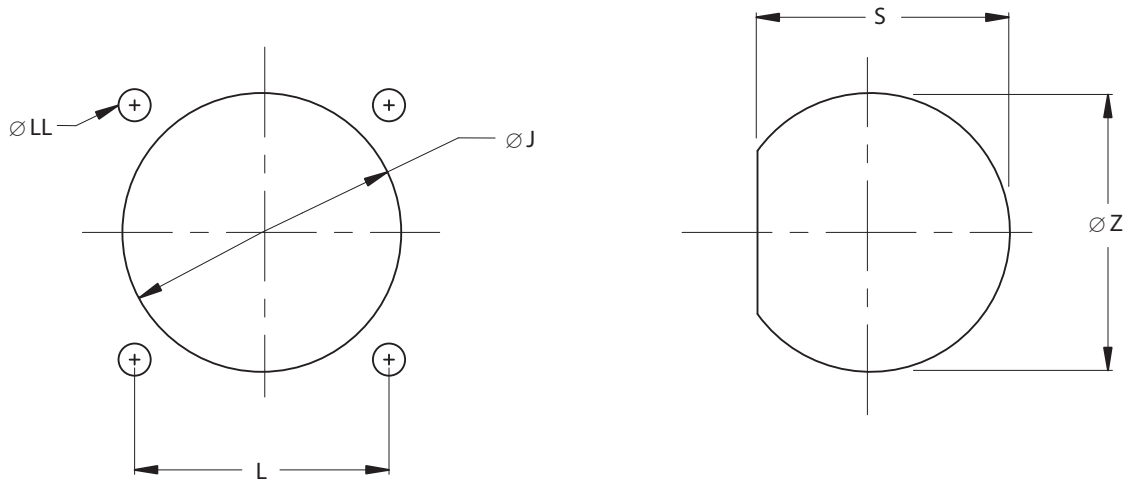

### Panel Thickness

Receptacle Type	Rear Mounting		Front Mounting	
	inch	mm	inch	mm
Wall Mount Receptacle, Bayonet	.250 max*	<b>6.36 max*</b>	.125 max	<b>3.18 max</b>
Wall Mount Receptacle, Threaded	.125 max	<b>3.18 max</b>	.125 max	<b>3.18 max</b>
Jam Nut Mount (Bayonet & Threaded)	.062/.125	<b>1.57/3.18</b>	—	—

\* Includes screw-head

### Flange and Jam Nut Mounting Dimensions

Shell Size	L		$\varnothing J$		$\varnothing J$		$\varnothing LL$		S		$\varnothing Z$	
	(TP)		For Back Mounting Minimum		For Front Mounting Minimum		+.000	+.00	$\pm .005$		$\pm .005$	$\pm .13$
	inch	mm	inch	mm	inch	mm	-.009	-.23	inch	mm	inch	mm
8	.594	<b>15.09</b>	.620	<b>15.75</b>	.510	<b>12.95</b>	.125	<b>3.18</b>	.605	<b>15.37</b>	.635	<b>16.13</b>
10	.719	<b>18.26</b>	.748	<b>19.00</b>	.635	<b>16.13</b>	.125	<b>3.18</b>	.730	<b>18.54</b>	.760	<b>19.30</b>
12	.812	<b>20.62</b>	.918	<b>23.32</b>	.760	<b>19.30</b>	.125	<b>3.18</b>	.917	<b>23.29</b>	.947	<b>24.05</b>
14	.906	<b>23.01</b>	.988	<b>25.10</b>	.885	<b>22.48</b>	.125	<b>3.18</b>	.980	<b>24.89</b>	1.010	<b>25.65</b>
16	.969	<b>24.61</b>	1.114	<b>28.30</b>	1.010	<b>25.65</b>	.125	<b>3.18</b>	1.105	<b>28.07</b>	1.135	<b>28.83</b>
18	1.062	<b>26.97</b>	1.220	<b>30.99</b>	1.072	<b>27.23</b>	.125	<b>3.18</b>	1.229	<b>31.22</b>	1.260	<b>32.00</b>
20	1.156	<b>29.36</b>	1.346	<b>34.19</b>	1.197	<b>30.40</b>	.125	<b>3.18</b>	1.354	<b>34.39</b>	1.385	<b>35.18</b>
22	1.250	<b>31.75</b>	1.470	<b>37.34</b>	1.322	<b>33.58</b>	.125	<b>3.18</b>	1.479	<b>37.57</b>	1.510	<b>38.35</b>
24	1.375	<b>34.93</b>	1.596	<b>40.54</b>	1.442	<b>36.63</b>	.154	<b>3.91</b>	1.604	<b>40.74</b>	1.635	<b>41.53</b>

MIL-DTL-83723 S III

**MIL-DTL-83723****Contacts, Tools and Seal Plugs  
Series III****Contacts, Plastic Insertion/Removal Tools and Seal Plugs**

Contact Size	Application	Pin Contacts	Socket Contacts	Seal Plugs	Insertion/Removal Tools
	Type	Military No.	Military No.	Military No.	Military No.
20	Power/Signal	M39029/4-110	M39029/5-115	MS27488-20-1	M81969/14-11
16	Power/Signal	M39029/4-111	M39029/5-116	MS27488-16-1	M81969/14-03
12	Power/Signal	M39029/4-113	M39029/5-118	MS27488-12-1	M81969/14-04

**Crimping and Metal Insertion/Extraction Tools**

Contact Size	Crimp Tool	Positioner	Positioner	Insertion Tool	Extraction Tool
	Military No.	Military No.	Military No.	Military No.	Military No.
20	M22520/1-01	M22520/1-02	M22520/1-02	M81969/8-205	M81969/8-206
	M22520/2-01	M22520/2-02	M22520/2-02		
16	M22520/1-01	M22520/1-02	M22520/1-02	M81969/8-207	M81969/8-208
12	M22520/1-01	M22520/1-02	M22520/1-02	M81969/8-209	M81969/8-210

**Contact and Wire Data**

Contact Size	Test Current	Voltage	Crimp Well Data			Wire Range	Finished Wire $\varnothing$ Range				
	DC Test	Max. Drop	Well Dia.	Minimum Well Dept		AWG	Minimum		Maximum		
	Amps	Millivolts	inch	inch	mm		inch	mm	inch	mm	
20	7.5	55	.049 $\pm$ .001	.155	3.94	24-20	.20-.52	.040	1.02	.083	2.11
16	13.0	49	.067 $\pm$ .001	.250	6.35	20-16	.52-1.31	.053	1.35	.103	2.62
12	23.0	42	.100 $\pm$ .002	.250	6.35	14-12	2.08-3.31	.097	2.46	.158	4.01

**Note:** Test Current and Maximum Voltage Drop when tested with silver-plated wire at 25°C.



## MIL-DTL-83723 Series III Contact Installation Instructions Bayonet and Threaded Coupling

### Contact Installation Instructions

#### Crimping Contacts

1. Select the appropriate crimp tool and ensure that the proper crimp head positioner is used.
2. Cycle the tool to be sure the indentors are open.
3. Determine the correct selector setting for the wire size from the data plate on the positioner (turret head assembly) and set the selector knob on the crimp tool to match.
4. Place the contact, mating end first, into the tool.
5. Insert the stripped wire into the hollow end of the contact. Be sure the wire is inserted as far as it will go.
6. Close the tool completely to crimp. Unless the tool is closed completely, the tool will not release the contact.
7. Remove the crimped contact from the tool. Check the inspection hole to verify that the wire is fully inserted.

#### Insertion of Contacts

1. Before inserting the contacts, unscrew the accessories (clamps, backshells or adapters) from rear of plug or receptacle. Slide the hardware over the wire bundle in the proper order for reassembly after all the contacts are inserted.
2. To assist insertion of contacts, lubricate insulator (grommet) cavities with isopropyl alcohol. Alcohol will evaporate and will not leave a conductive film. **Caution: Never use any lubricant other than isopropyl alcohol.**

3. Place the correct insertion tool on the contact so that the wire runs along the groove in the tool. (Tool tip will butt against the shoulder.) Hold the plug or receptacle body firmly.
4. Beginning with a center cavity, insert the contact into the insulator with a slow, even pressure until the contact snaps into position. Make sure the contact and tool are held perpendicular to the face of the insert during the contact installation or the grommet could be damaged.
  - 4.1 If contacts are not inserted all the way prior to removing insertion tool, do not try to reinsert the insertion tool. Instead, remove the contact and try again; otherwise reinserting the insertion tool may damage the inside of the contact cavity.
5. Remove tool and check the face of the connector for proper contact installation. Proper installation may also be checked by pulling back lightly on the wire to make sure the contact is properly seated.

#### Completion

After all the cavities have been filled, slide the hardware back into position on the connector and tighten.

#### Extraction of Contacts (Rework)

1. Slide the hardware back over the wire bundle.
2. Select the appropriate tool. Place the wire into the extraction tool of the pin or socket.
3. Slowly slide the extraction tool down wire into the contact cavities until the tool tip bottoms against the contact shoulder, expanding the clip retaining tines. Hold the wire firmly in the tool and pull the wired contact and tool straight out of the rear of the insulator.

Size	Pin Contact	Socket Contact	Basic Crimp Tool	Pin Positioner	Socket Positioner	Insertion/Removal Tool
20	M39029/4-110	M39029/5-115	M22520/1-01	M22520/1-02 Red	M22520/1-02 Red	M81969/14-11
			M22520/2-01	M22520/2-02	M22520/2-02	
16	M39029/4-111	M39029/5-116	M22520/1-01	M22520/1-02 Blue	M22520/1-02 Blue	M81969/14-03
12	M39029/4-113	M39029/5-118	M22520/1-01	M22520/1-02 Yellow	M22520/1-02 Yellow	M81969/14-04

**MIL-DTL-83723 Series III**  
**Insert Availability and Contact Information**  
**per MIL-STD-1554**



Insert Availability and Contact Information

Insert Arrangement	Aero-Electric		Total	Quantity of Contacts				Service	Alternate Positions**				
	Status		No. of	(by Size)					(Insert Rotation in Degrees)				
	QPL'd	Tooled	Contacts	20	16	12	# 8coax	Rating	1	2	3	4	5
8-2Δ	Yes	Yes	2	2				I	N/A	N/A	N/A	N/A	N/A
8-3	Yes	Yes	3	3				I	N/A	N/A	N/A	N/A	N/A
8-98	Yes	Yes	3	3				I	N/A	N/A	N/A	N/A	N/A
10-2	Yes	Yes	2	2				I	10	20	30	40	50
10-5	Yes	Yes	5	5				I	10	20	30	40	50
10-6	Yes	Yes	6	6				I	10	20	30	40	50
10-20	Yes	Yes	2		2			I	10	20	30	40	50
12-3	Yes	Yes	3		3			I	10	20	30	40	50
12-12	Yes	Yes	12	12				I	10	20	30	40	50
14-4	Yes	Yes	4			4		I	10	20	30	40	50
14-7	Yes	Yes	7		7			I	10	20	30	40	50
14-12	Yes	Yes	12	9	3			I	10	20	30	40	50
14-15	Yes	Yes	15	15				I	10	20	30	40	50
16-10	Yes	Yes	10		10			I	10	20	30	40	50
16-24	Yes	Yes	24	24				I	10	20	30	40	50
18-8	Yes	Yes	8			8		I	10	20	30	40	50
18-14	Yes	Yes	14		14			I	10	20	30	40	50
18-31	Yes	Yes	31	31				I	10	20	30	40	50
20-16	Yes	Yes	16		16			I	10	20	30	40	50
20-25	Yes	Yes	25	19		6		I	10	20	30	40	50
20-28	Yes	Yes	28	24		4		I	10	20	30	40	50
20-39	Yes	Yes	39	37	2			I	10	20	30	40	50
20-41	Yes	Yes	41	41				I	10	20	30	40	50
22-12	Yes	Yes	12			12		I	10	20	30	40	50
22-19	Yes	Yes	19		19			I	10	20	30	40	50
22-32	Yes	Yes	32	26		6		I	10	20	30	40	50
22-55	Yes	Yes	55	55				I	10	20	30	40	50
24-19	Yes	Yes	19			19		I	10	20	30	40	50
24-29*	N/A	Yes	29		29			I	10	20	30	40	50
24-30*	N/A	Yes	30		30			I	10	20	30	40	50
24-43	Yes	Yes	43	23	20			I	10	20	30	40	50
24-57	Yes	Yes	57	55		2		I	10	20	30	40	50
24-61	Yes	Yes	61	61				I	10	20	30	40	50
28-42*	N/A	Yes	42		42			I	10	20	30	40	50

\* Non MIL-STD-1554 layout, available to Aero-Electric part number only.  
 Δ Consult factory for pin insert availability.

\*\* Alternate clocking positions (1, 2, 3, 4, and 5) are for interchangeability use only. Inactive for new design per MIL-STD-1554.

Insert Arrangement Views

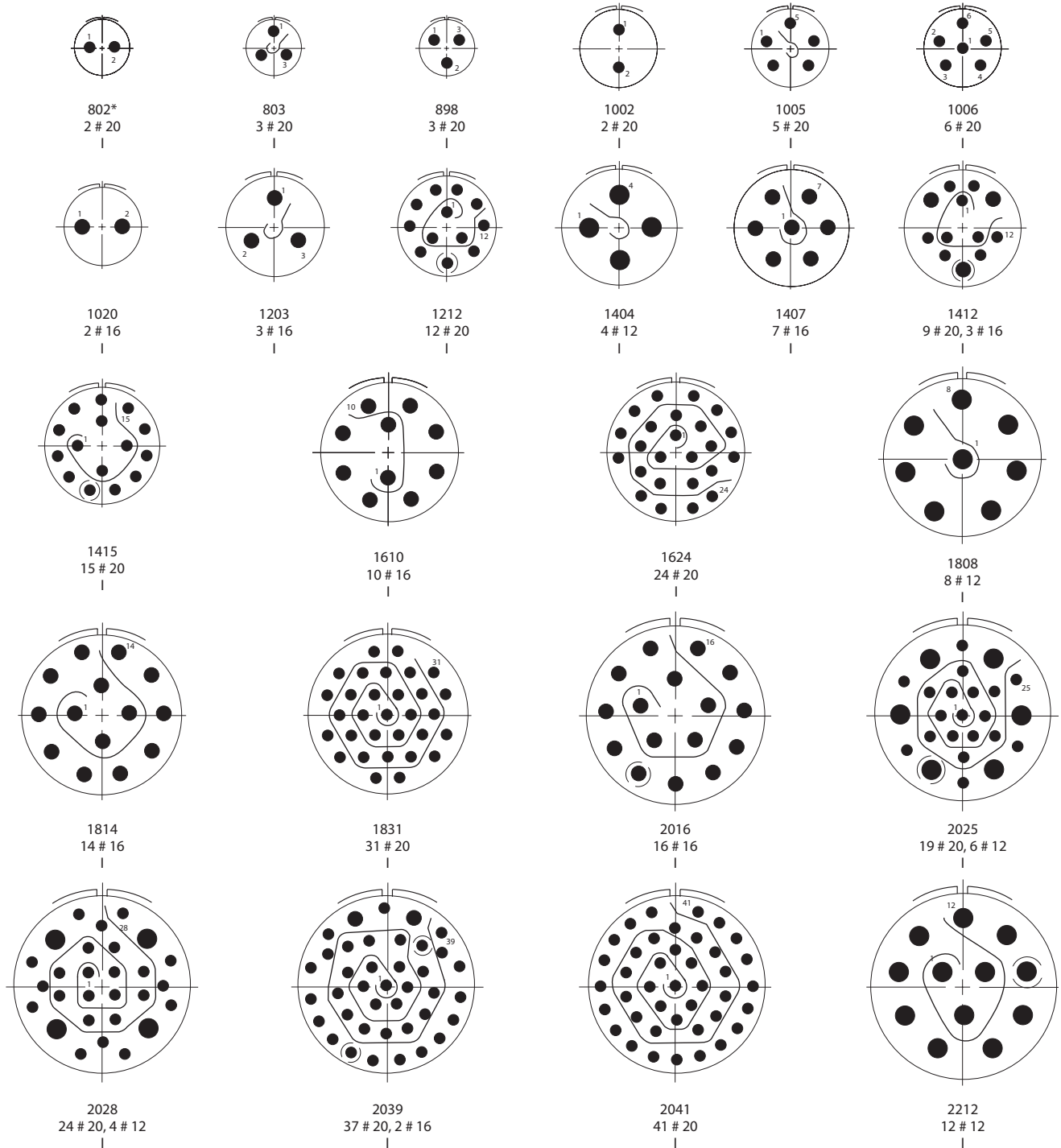

\* Consult factory for pin insert availability.

# MIL-STD-1554

## Insert Arrangements (Socket Front View) for MIL-DTL-83723 Series III Connectors



### Insert Arrangement Views

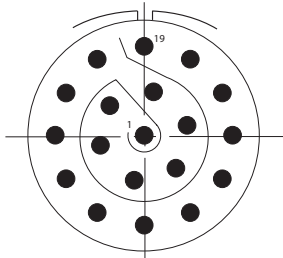

2219  
19 # 16

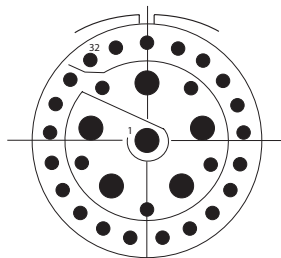

2232  
26 # 20, 6 # 12

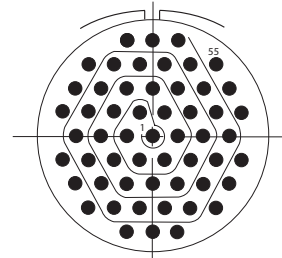

2255  
55 # 20

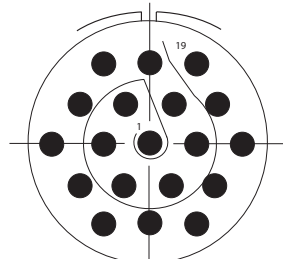

2419  
19 # 12

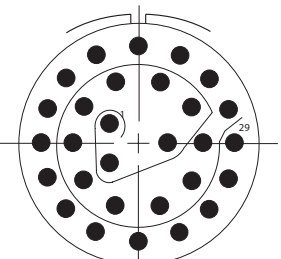

2429Δ  
29 # 16

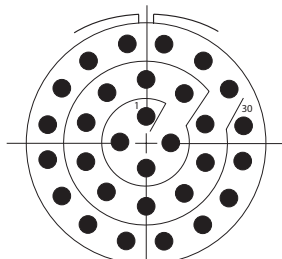

2430Δ  
30 # 16

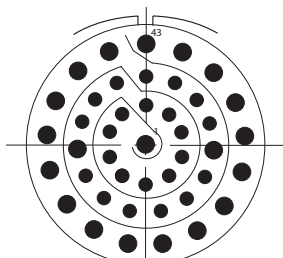

2443  
23 # 20, 20 # 16

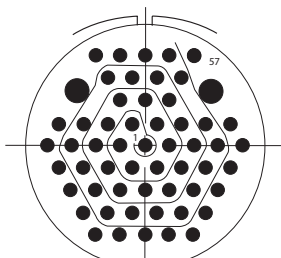

2457  
55 # 20, 2 # 12

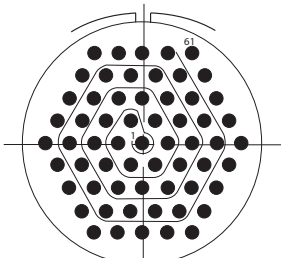

2461  
61 # 20

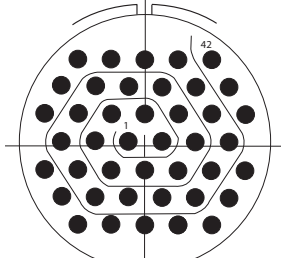

2842Δ  
42 # 16

MIL-DTL-83723 S III

Δ Non MIL-STD-1554 layout, available to Aero-Electric part number only.